

## 2 - COLOR PHOTODIODE

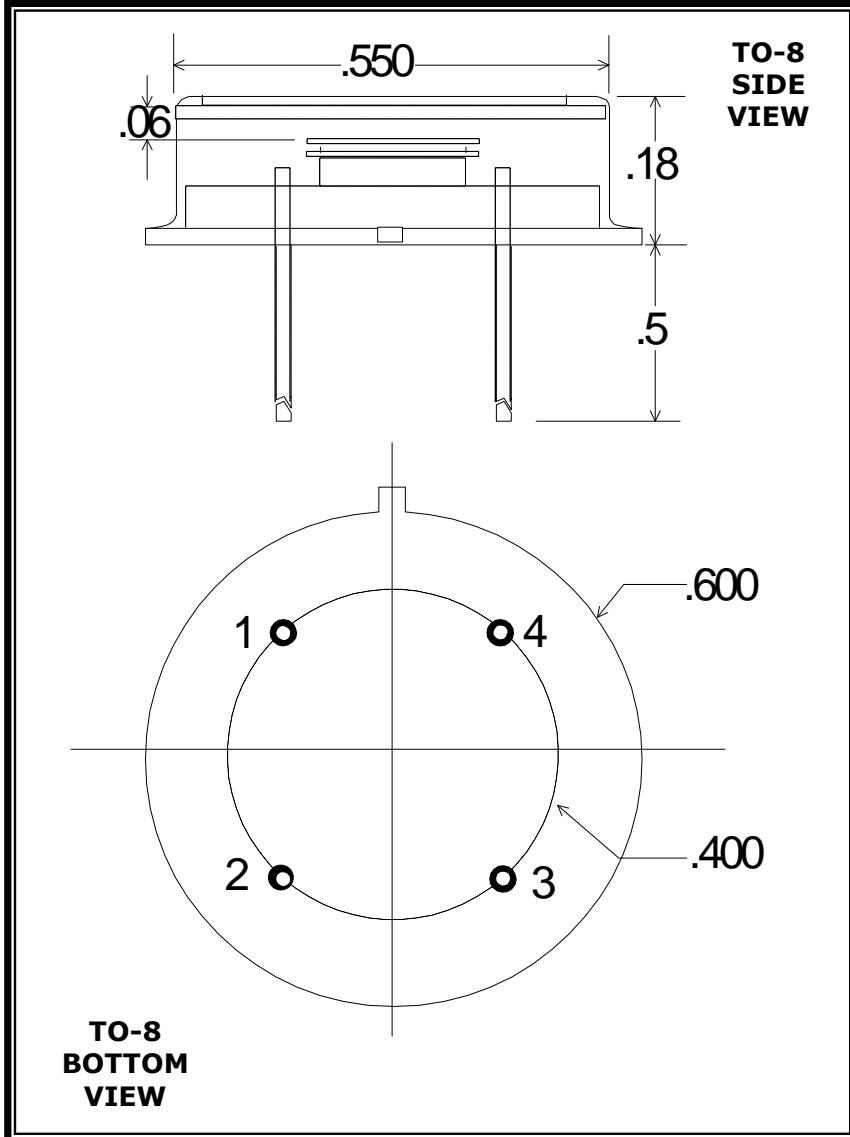

**Part No:** S/IGA - 050/030

**PIN OUT**

- 1 = TOP CATHODE
- 2 = TOP ANODE
- 3 = BOTTOM ANODE
- 4 = BOTTOM CATHODE

**Note:**

Dimensions in millimeters

### Application Note

ELECTRO OPTICAL SYSTEMS offers a variety of room temperature 2-color photodiode detectors. The units have state-of-the-art sensitivity and are supported by accessories such as optical filters, integral preamplifiers, and fiber optic connectors.

These units find applications in industrial control systems, test equipment, thermal sensors, and general infrared instrumentation.

### SPECIFICATIONS

Detector Position	TOP	BOTTOM
Detector Type	Si Photodiode	InGaAs Photodiode
Active Diameter (mm)	5	3
Operating Wavelength ( $\mu\text{m}$ )	0.3 - 1.0	1.0 - 1.7
Shunt Resistance ( $\Omega$ )	200 M	5 M
Shunt Capacitance (pF)	1500 typ	1000 typ
Responsivity (A/W)	0.5 @ 0.9 $\mu\text{m}$	0.6 @ 1.3 $\mu\text{m}$
NEP ( $\text{W}/\text{Hz}^{1/2}$ )	$< 1.5 \times 10^{-14}$	$< 1.5 \times 10^{-13}$

RoHS Compliant